



Geotechnical and Structural Challenges over an Active Landslide

Konstantinos Seferoglou, Civil Engineer, M.Sc., Odotechniki Ltd, Athens, Greece,
email: personal.sef@gmail.com

Isabella Vassilopoulou, Civil Engineer, Ph.D., Odotechniki Ltd, Athens, Greece,
email: isabella@central.ntua.gr

Fragiskos Chrysohoidis, Engineering Geologist, M.Sc., Odotechniki Ltd, Athens, Greece,
email: franxgr@hotmail.com

ABSTRACT: The construction of the steel arched Tsakona Bridge, designed to overpass an active landslide, required several temporary projects. Auxiliary steel towers were used for the erection and welding of the arch segments. Most of them had to be founded in the body of the sliding mass. An automated instrumentation and monitoring system was installed on site providing early warning to the engineers in charge in case large displacements were measured. The real-time recording data provided valuable information about the landslide movements. These monitoring results defined the geotechnical and structural design criteria for the deep foundation of the temporary towers. Several 2D and 3D geotechnical and structural models were created to evaluate the sliding effect on the foundation components, finalize their dimensioning and calculate the required reinforcement. The procedure followed for the design of the temporary deep foundation is described based on the criteria devised using the monitoring system, emphasizing on the continuous feedback between the geotechnical and structural design teams. Several key structural design issues required during construction are also presented.

KEYWORDS: geotechnical and structural design, deep foundation, temporary piers, geotechnical monitoring, active landslide, sliding movements.

SITE LOCATION: [Geo-Database](#)

INTRODUCTION

The highway to the city of Kalamata in southern Peloponnese crossed through an old landslide, which was reactivated in January 2003 after a period of heavy rainfalls, leading to a major catastrophic slide. The triggered landslide is one of the largest that have occurred in Greece, the consequences of which are shown in Figure 1. Horizontal and vertical displacements of the sliding mass up to 100 m and 40 m, respectively, were measured, causing a soil mass movement of about 6,000,000 m³ of flysch colluvia and manmade deposits, extended in a large area of 400 m upslope and 700 m downslope of the highway (Belokas 2013, Belokas and Dounias 2016). Among several options studied for the rehabilitation of the National Highway, bridging over the landslide was selected as the most cost-efficient and technically feasible solution (Fikiris et al. 2011). The steel arched Tsakona Bridge, sketched in Figure 2, was decided to be constructed over the sliding mass, which moved downslope at an average rate of about 1.5-2.0 mm/month. This rate was increasing significantly during the periods of intense rainfalls, exceeding for short periods of time the value of 30 mm/month (projected rate of movement).

The 390 m long Tsakona Bridge consisted of 130 m long access part of prestressed concrete deck and a steel arch with a completely suspended steel deck of 260 m length. The abutments and the V-shaped pier were made of reinforced concrete, seated outside the limits of the landslide on stable ground (Fikiris et al. 2011). The erection of the bridge arch required fourteen (14) twin steel temporary auxiliary towers, reaching a maximum height of about 60 m. The towers were anchored on piers, and consisted of pile groups (Figure 3). For the left (East) upslope branch of the Highway seven piers named as Π1A-Π7A were built with pile lengths 5 m and 8 m. For the right (West) downslope branch of the Highway, another seven piers were constructed, named as Π1Δ- Π7Δ, with pile lengths that varied between 8 m for the pier Π7Δ and 32 m for Π1Δ.

Submitted: 31 December 2016; Published: 2 March 2018

Reference: Seferoglou, K., Vassilopoulou, I. and Chrysohoidis, F. (2018). *Geotechnical and Structural Challenges Over an Active Landslide*. International Journal of Geoengineering Case Histories, Vol.4, Issue 3, p.162-184.

doi: 10.4417/IJGCH-04-03-02



Figure 1. The Tsakona landslide (February 2003) (EMEK S.A (2015)) (a) large settlements on the road pavement (b) massive soil movement (Fikiris et al. (2001)).

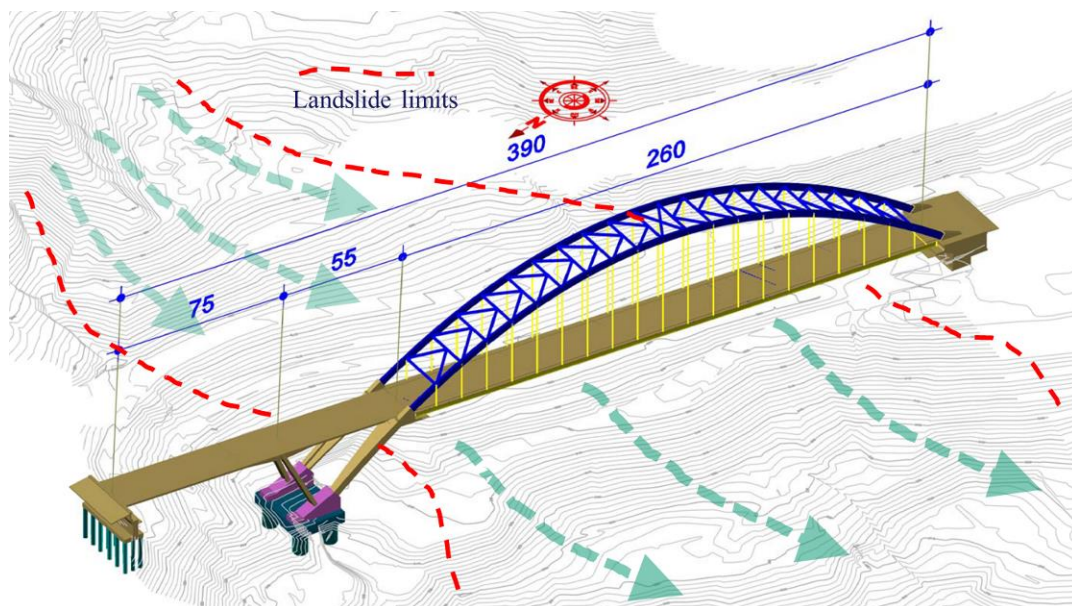

Figure 2. The Tsakona Bridge overpassing the active landslide.

The four middle pairs of these piers (II2-II5) were expected to be affected mostly by the evolving movements of the landslide as they were totally founded in the central most active part of the sliding mass. Between the piers, corridors were also designed for the pre-assembly of the arch and deck segments. They were formed as slabs on the ground, except a part of the west branch corridor that was replaced with small temporary bridges on pile systems, due to the steep morphology of the ground, to minimize the loads applied on the slopes of the sliding mass. Two heavy duty towers were also mounted at the end of the V-shaped pier of the bridge, beneath the support of the arch, to ensure stability during the construction of the pier and the erection of the arch and the deck. These towers, named as MTA for the east branch and MTA for the west one, remained in-place until the completion of the entire bridge. The described foundation projects are illustrated in Figure 4. Additionally, a pile-wall was also designed to retain the temporary diversion of the Highway, passing on top of the sliding body, ensuring the safety of the traffic of a fully operational road, as well as the activities on-site. Finally, scaffolding towers with deep foundations were also used for casting the prestressed concrete deck between the northern abutment and the pier of the bridge. All these temporary structural projects, combined with earthworks (excavations and embankments), should be reduced to the minimum possible to resist additional loads that could threaten the stability of the landslide body. A general view of all works is provided in Figure 5. Due to the high risk of the active landslide, a detailed geotechnical



monitoring campaign was developed, deemed as a prerequisite for a successful and safe construction. The monitoring network utilized all the previously installed conventional instruments (inclinometers, piezometers and optical targets) and it was extended with a supplementary network of fully automated instruments of inclinometers, piezometers, as well as rain and wind gauges. Data collected on a real time basis were used to optimize the design of the works and simultaneously support the assessment of the risk associated with the landslide during the construction period. The construction consulting team (ODOTECHNIKI Ltd) worked closely with the contractor to implement all the geotechnical, structural and monitoring design requirements related to the temporary infrastructure works, while bridge and the construction methodology was previously decided by the designers of the bridge (DOMI S.A. & EDAFOS S.A.) and approved by the authorities.

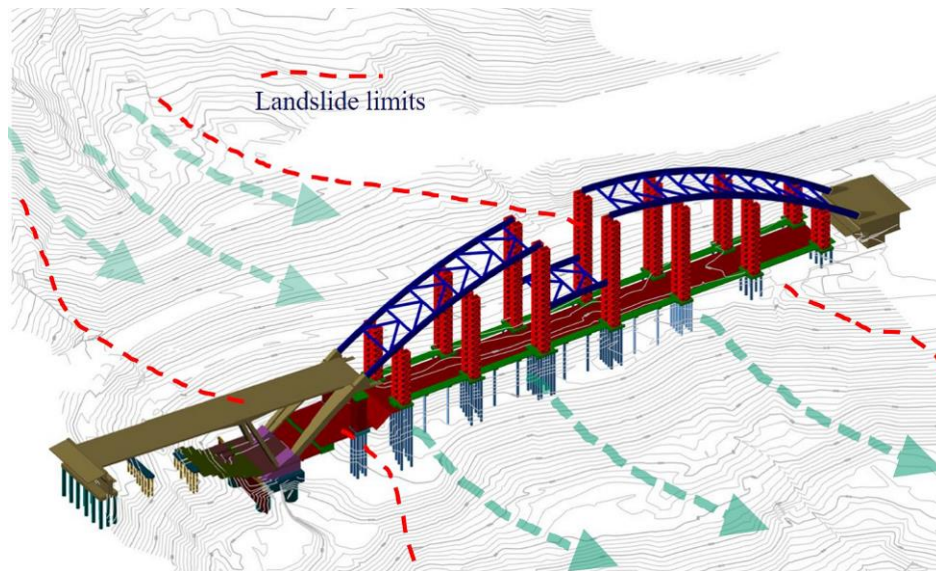

Figure 3. Arch erection of the Tsakona Bridge using temporary steel towers.

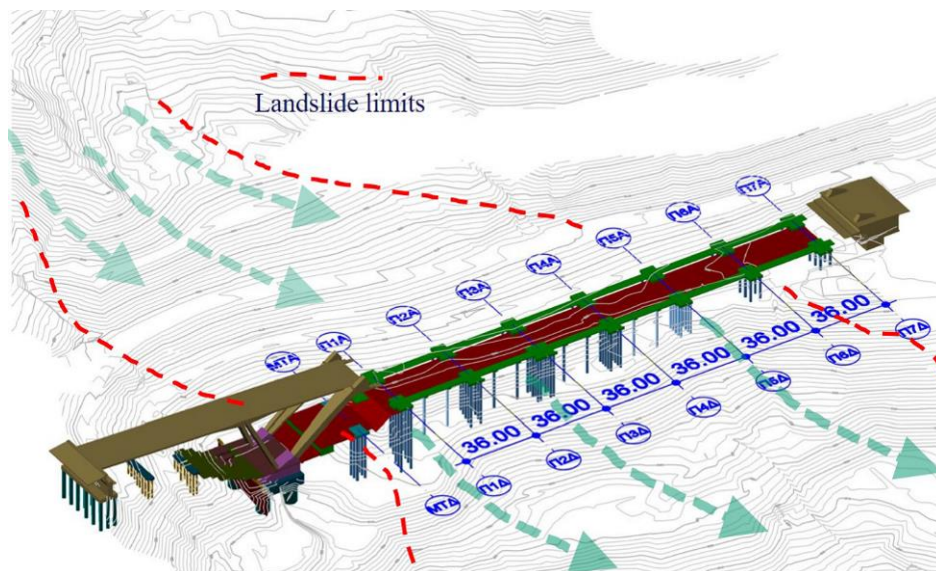

Figure 4. The temporary infrastructure projects. Pier P1 through P7 are shown. P1A is for the eastern P1 and P1A is for the western P1. Dimensions in m.

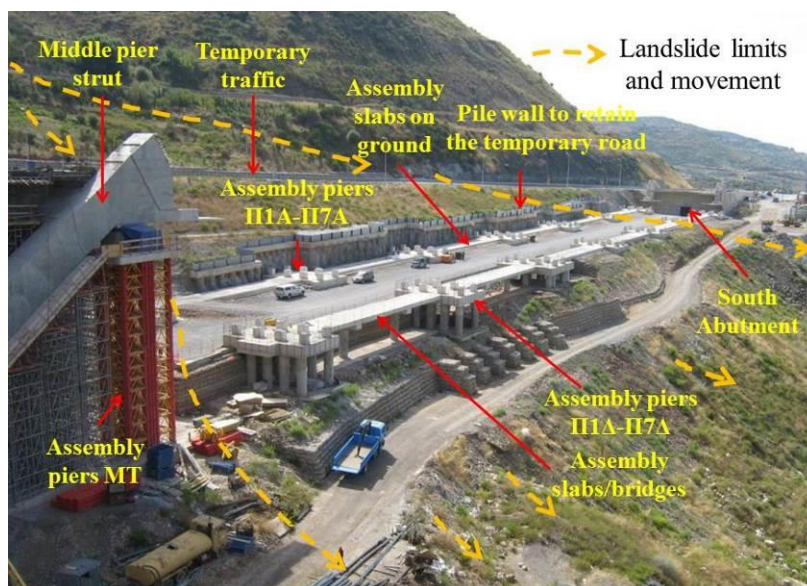

Figure 5. General view of the worksite with the temporary projects.

Two-dimensional (2D) and three-dimensional (3D) finite element models were set up and a series of geotechnical and structural numerical analyses were conducted. The objective was to simulate the exact profile of the sliding mass at each location of the fourteen (14) temporary pile groups along the bridge, evaluate the influence of the imposed movements on the piles, determine the parameters that would better describe the soil-structure interaction under sliding conditions, namely the earth pressure coefficient and equivalent spring constants at the bottom of the piles, and perform the final structural design of the temporary piers. Important engineering issues that defined the final setup of all temporary structures were: (a) ensuring of a safe working environment during the construction period, (b) minimizing disturbance of the slope equilibrium, (c) the arrangement of the piles and especially their depth with respect to the steep underlying bedrock and (d) the cost optimization, which was always one of the key requirements of the contractor.

An outline of the structural and geotechnical design of the towers' foundation was included in Vassilopoulou and Seferoglou (2016). A more detailed description of the whole project is given in this paper, pointing out the difficulties that had to be encountered during construction. The monitoring system is delineated and the evaluation and the main results of the elaborated recorded data are presented, leading to the main assumptions of the deep temporary foundation design. Emphasis is given in the methodology followed for the final design of the towers foundation, discussing also the behaviour of the pile-groups to the imposed movements of the landslide.

GEOLOGICAL AND GEOTECHNICAL CONDITIONS

The geotechnical investigation in the area as well as the interpretation of the results were carried out and approved at the stage of the bridge design and was adopted for the needs of the works described in the present article. The geotechnical interpretation provided the design parameters, presented in Table 1, which were used in all further analyses. In the area of the landslide, the bedrock geology consists of a flysch-like formation where sandstones and siltstones/pelites prevail. The products of weathering of these formations cover the bedrock up to a depth of 40 m in some cases. The area of the landslide is characterized by a morphological depression, which formed the basin for the deposited weathered material. The sliding surface is located at the contact of these soil type materials (weathering products) and rock formations. Characteristic transverse sections are illustrated in Figures 6 through 8, showing the bedrock/soil interface.

Table 1. Geotechnical design parameters.

Geotechnical unit	Geotechnical Design Parameters
Soil Material (mainly scree and weathered flysch)	Peak values: $\gamma=21.5 \text{ kN/m}^3$, $c_p=5 \text{ kPa}$, $\phi_p=25-28^\circ$, $E=20-30 \text{ MPa}$ Residual values (Shear zone along the sliding surface): $c_r=0 \text{ kPa}$, $\phi_r=16-20^\circ$
Bedrock (flysch-like formation)	Sandstone GSI=35: $\gamma=25 \text{ kN/m}^3$, $c=165 \text{ kPa}$, $\phi=56^\circ$, $E=2.6 \text{ GPa}$ Siltstone GSI=16: $\gamma=25 \text{ kN/m}^3$, $c=42 \text{ kPa}$, $\phi=31^\circ$, $E=0.4 \text{ GPa}$

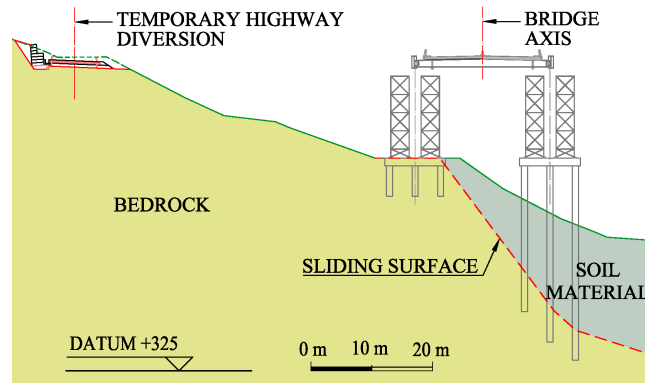

Figure 6. Geological section at Pier III.

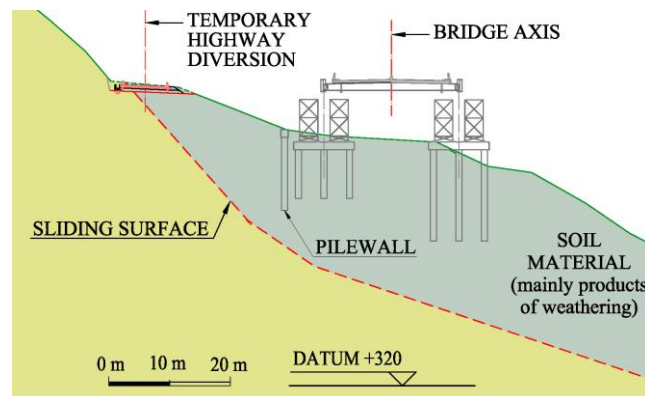

Figure 7. Geological section at Pier II5.

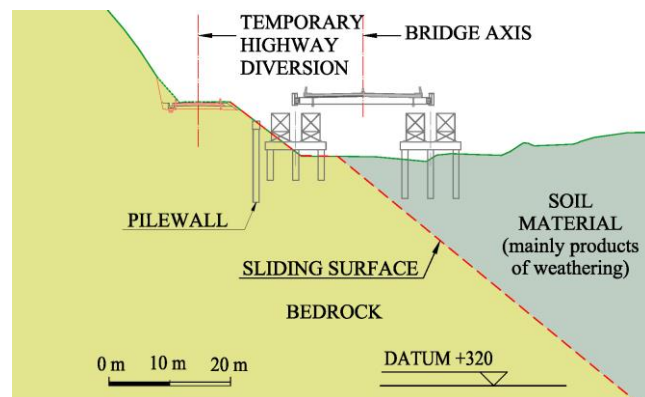

Figure 8. Geological section at Pier II7.

The landslide behaviour and therefore the remediation geotechnical design were greatly influenced by 3 critical geological features: (a) the variable (10 m – 35 m) thickness of the loose material (mainly scree and weathered rock) overlaying the bedrock (limestone, flysch-like formation of red pelites-sandstones-siltstones) (b) the underground topography of the bedrock surface, with an inclination ranging from mild (12°) to moderately steep (30°) or locally even steeper (40°) and (c) the groundwater regime, especially with regard to the underground springs occurring at the limestone/flysch interface, feeding the landslide mass and adversely influencing its stability (through water pressure). The described adverse conditions introduced uncertainties regarding the proper geotechnical section that should be selected for the design, while at the same time they increased the risk of sudden local failures within the area of the project. These uncertainties and risks had to be studied in the context of the landslide activity, the demanding erection works of the bridge arch and the safety requirements of the highway traffic, which, while temporary, would still rest on the landslide body. The aforementioned conditions required a realistic evaluation and understanding of the sliding mass behaviour and its close monitoring during construction.



ADDRESSING MAIN CONSTRUCTION CHALLENGES

Construction of the Bridge Pier

The main body of the V-shaped pier consisted of two pairs of supporting struts. The southern struts were curved, following the parabolic geometry of the arch. The northern ones were designed as straight elements on the same inclined plane, converging towards each other. For the construction of the curved struts, scaffolding towers were used, anchored on slabs on the ground. For the straight struts a self-climbing formwork system was mobilized. Temporary horizontal bracings along the transverse direction kept the straight struts in place. At the same time, temporary tendons were utilized to suspend these struts from the completed curved ones, providing the necessary stability to the unfinished V-shaped pier (Figure 9). Before the construction of the curved struts, the two MT towers were installed to support their top ends. They were designed to provide bearing capacity of 12000 kN and 16500 kN each, under static and seismic load combination, respectively. Their foundation consisted of pile-groups penetrating the stable bedrock, connected with pile caps. Ground anchors were also foreseen, as mitigation measure to be activated in case large movements were observed during construction (Figure 10). A special arrangement was provided on the top of the MT towers to compensate any contingency movement within the loose soil above the bedrock as well as the elastic deformations of the auxiliary towers and the deformation due to temperature fluctuations. This arrangement included two (2) elastomeric bearings and four (4) lifting jacks for each tower. Continuous accurate surveying of the level of the bearings and vertical adjustments through the jacks were ensuring the fixed vertical position of the support during construction, until the complete functionality of the arch was achieved.



(a)



(b)

Figure 9. Construction of the (a) curved struts and (b) straight struts of the bridge pier.

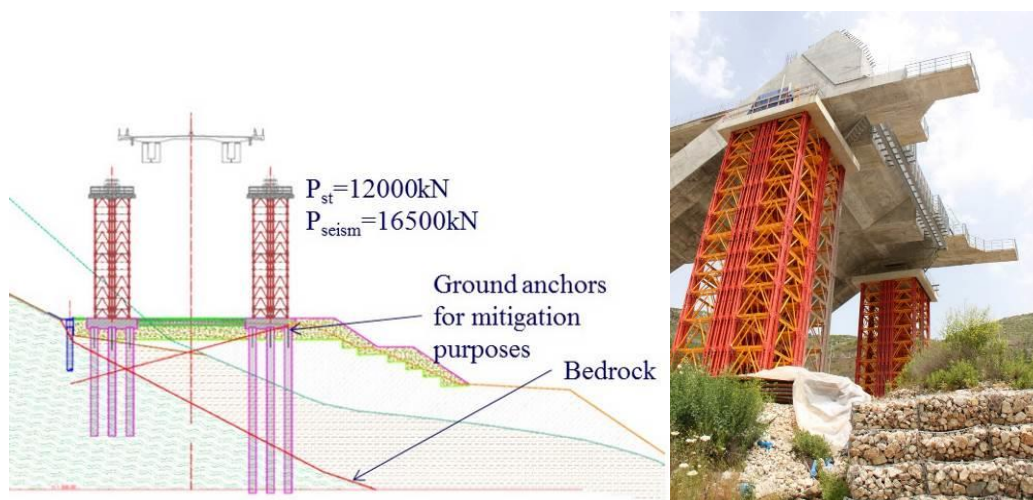

Figure 10. Arrangement of the MT towers beneath the curved struts of the bridge pier.

Construction of the Bridge Superstructure

The 130 m prestressed concrete part of the bridge consisted of two parts, one 55 m long closing the V shape of the bridge pier and the other 75 m long between the straight struts of the pier and the northern abutment, as shown in Figure 11. The first part was poured on scaffolding anchored on the struts of the pier and ground slabs, while for the second one heavy duty bridge-type scaffolding was used, founded with piles on adverse surface morphology conditions, but on a stable ground (Figure 11). The construction of the bridge was completed with the steel arch part. The arch system with a span of 260 m and a rise of 45 m, consisted of two vertical steel arches, one for each branch of the Highway, connected with K-type bracings, all pre-fabricated. Segments of 12 m long were assembled and welded on the ground slabs or the bridge corridors, creating larger pieces of 36 m, which were in turn lifted to position with the heavy lifting system mounted on the temporary steel towers and welded at height. Shelter booths were seated at the top of the towers providing protection from the wind and the rain for the welding procedure of the arch segments (Figure 12a). The bridge was completed with the erection of the composite deck (Figure 12b), which was fully suspended from the arches with the use of hangers (Stathopoulos et al. 2014a, 2014b).



(a)



(b)

Figure 11. Construction of (a) the 55 m and (b) the 75 m access parts of the bridge prestressed concrete deck.



(a)



(b)

Figure 12. Assembling, erection and welding of (a) the arch segments using the auxiliary steel towers and (b) the composite deck segments.

Closure of the Arches with the Placement of the Key Segment

The length of the crown gap changed during a 24 hours cycle up to 4 cm, because of the high temperature differences, rendering difficult the welding of the key segment. The gap was fixed to a firm distance to allow the welding of the last “tailor made” piece of the arch, using steel plates and pins. Four connections were designed (Figure 13) to sustain a total tensile and compressive force between the constructed parts of the arch equal to 10000 kN, caused by a mean temperature difference of $\pm 15^{\circ}\text{C}$.

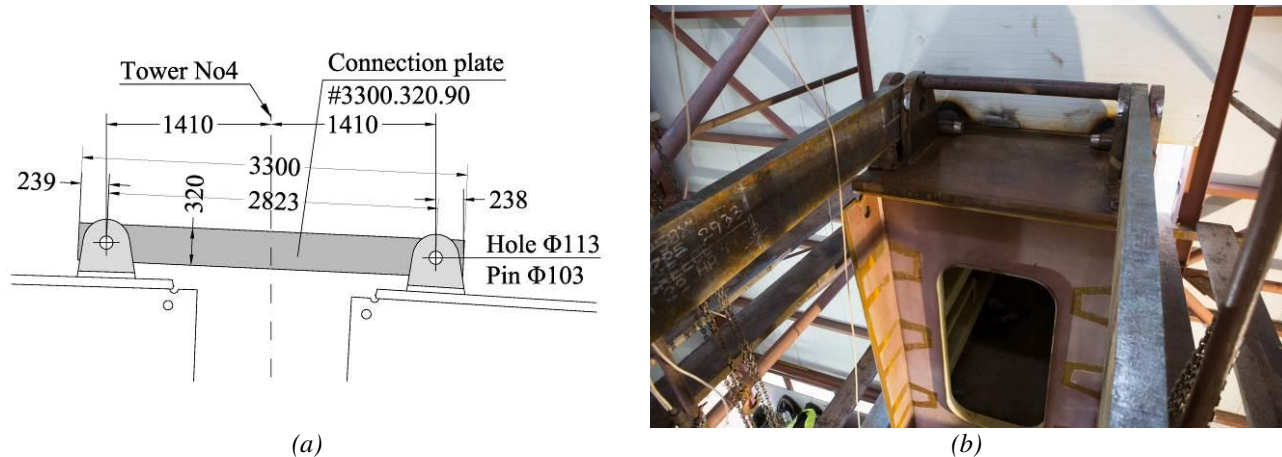

Figure 13. Connection arrangement for fixing the crown gap between the arch parts to weld the key segment (a) drawing (b) implementation.

Other Crucial Issues

Other crucial issues were related with gradual removal of the arch supporting towers (Figure 14), as well as the total release of the bridge and the removal of the last supporting structure, the MT towers.



Figure 14. Removal of the temporary towers.

INSTRUMENTATION – MONITORING – EARLY WARNING SYSTEM

In order to explore and deal with an active landslide, which presented very small margins of safety against failure, a network of geotechnical instruments that recorded the movements of the sliding mass and water levels was installed in the 2001-2012 period, comprising optical targets, inclinometers and piezometers. In January 2013, in view of the forthcoming high-risk construction works, a complementary fully automated instrumentation scheme was designed and implemented that continuously recorded, monitored and updated a database (Seferoglou and Chrysohoidis 2016). The instruments were located at key depths within the sliding mass and at positions near structural elements. The new instrumentation system consisted of four (4) in-place inclinometer chains in boreholes KA2, KA3, KA4 and KA5 (later relocated to KA2N, KA3N and KA5N), three (3) electrical piezometers (ΠΖ-2, ΠΖ-3 και ΠΖ-5) close to the boreholes KA2, KA3 and KA5 and a rain gauge (pluviometer). These instruments, along with the conventional ones, provided all the necessary information about the movement of the sliding mass and its impact on the structures. The arrangement of all instruments in plan-view is illustrated in Figure 15, while a characteristic section between piers Π2 and Π3 is shown in Figure 16, pointing out the position of the geotechnical instruments with respect to the bedrock surface.



- ◆ PB-i optical targets for surface movements
- ◆ Pii-Aj optical targets for movements of pier foundation
- ◆ Mi optical targets for movements of the pile wall
- IIZ-i automated permanent piezometers
- T4-KNi conventional inclinometers
- KA-i automated permanent inclinometers
- Pii conventional piezometers
- FN-i borehole (2001)

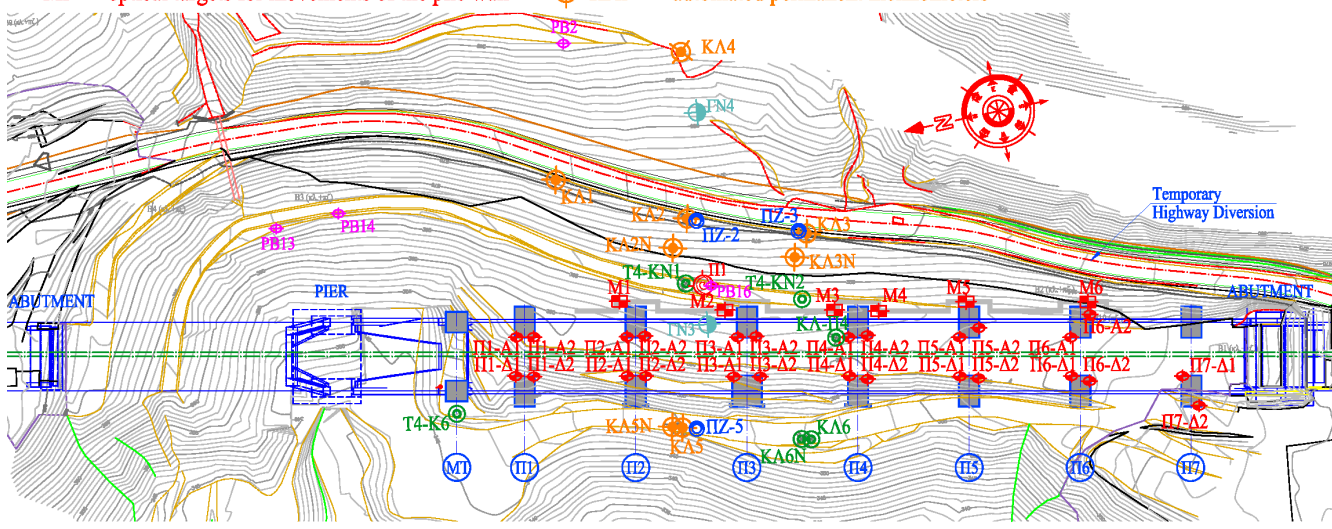

Figure 15. Arrangement of the geotechnical instruments in plan-view.

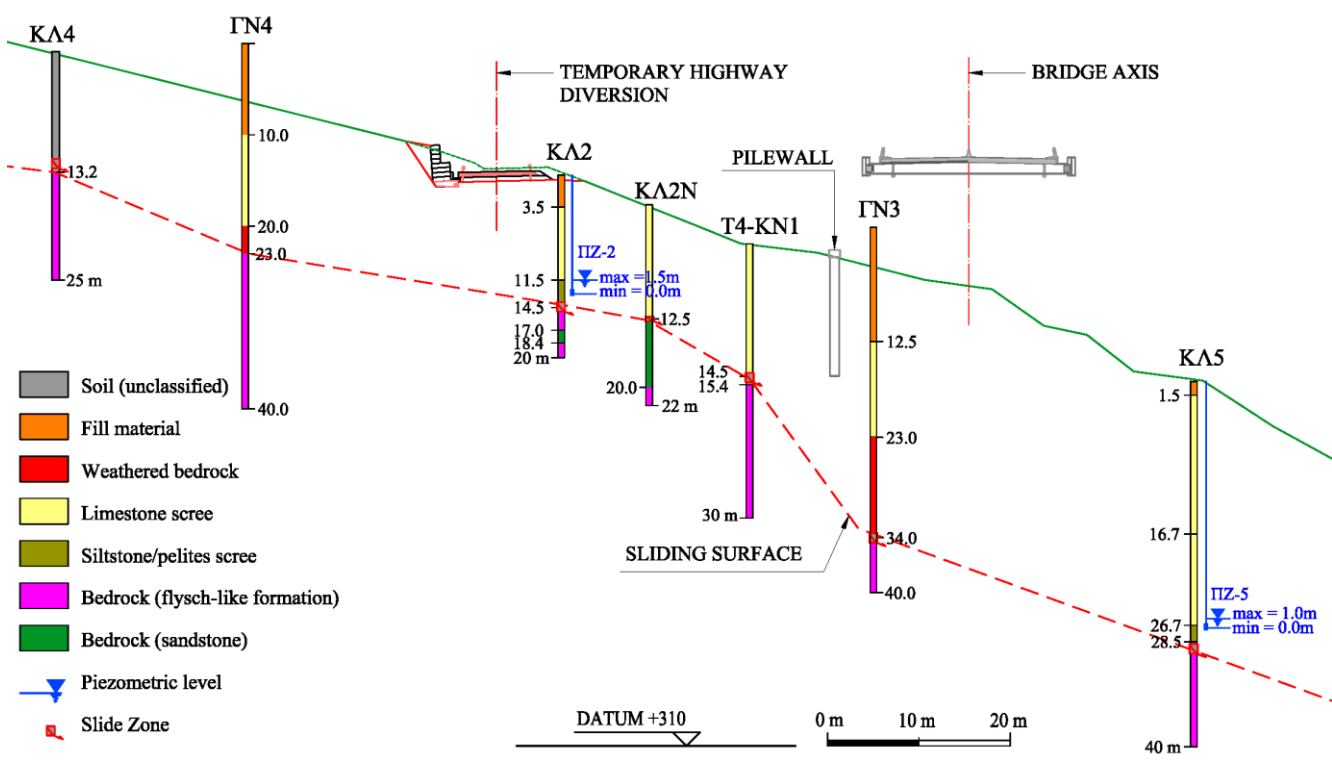

Figure 16. Section in between Piers I12 and I13 showing the position of the geotechnical instruments with respect to the bedrock surface.

The monitoring network continuously recorded the movements of the sliding mass and the piezometric levels. All automated sensors were recording in intervals of 2 – 4 hours, depending on landslide activity. All measurements were collected to a data logger and uploaded with the use of a GSM modem (Global System for Mobile communications) to the consulting office (ODOTECHNIKI Ltd) for a real-time evaluation using a software application developed for this specific



project. This application automatically processed the recorded data to information of engineering interest (displacements, piezometric level and rain level) updating representative tables and graphs for each instrument, continuously providing the evolution of the phenomena for further assessment and evaluation. The results of this procedure were uploaded to a shared cloud server every 4 hours, being accessible to the responsible design and construction teams, who could appraise the potential risk of the landslide any time at any point of the site. Apart from the continuous evaluation and analysis of the recording data, the data logger was setup to send SMS messages to the engineers in charge, in case large movements were recorded exceeding specific alert movement thresholds, initiating thus a series of increasing awareness and contingency actions. Several cases of excessive sliding movements as well as seismic events were noted during the construction period of the bridge and special instructions were issued to the construction team, especially during the winter season after incidents of intense rainfalls. The flow chart of the monitoring procedure is given in Figure 17. Two typical diagrams of the measured incremental and the calculated cumulative displacements in an automated inclinometer are given in Figure 18.

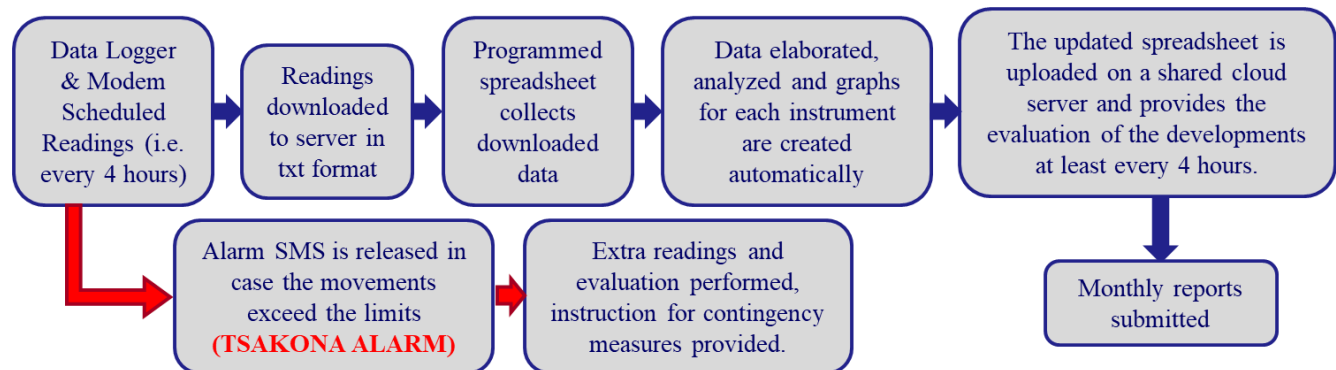

Figure 17. Automated monitoring procedure – Flow chart.

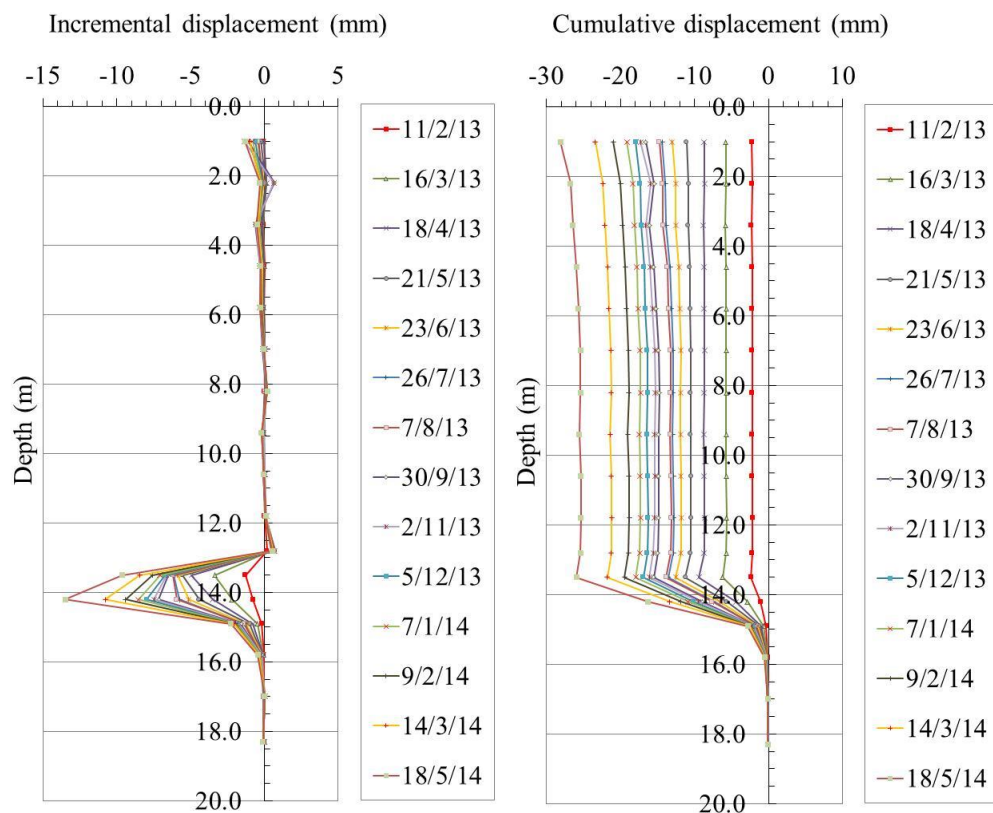

Figure 18. Typical diagrams of automated inclinometer K12 (measuring along the whole depth).



The data collected from the conventional instruments, as well as the results derived from the automated monitoring system were used to set the parameters for the geotechnical and structural analysis of the deep foundations within the sliding mass and optimize their design. The main conclusions drawn from monitoring results were the following:

- Differential horizontal and vertical displacements were observed between the piers of the two branches of the highway and between the piers of the same branch, as plotted in Figure 19. The maximum differential horizontal displacement was noted between piers Π1A and Π1Δ reaching 2.7 cm, while the maximum vertical displacement was measured between piers Π2A and Π2Δ, being equal to 2.4 cm.
- The rate of the sliding movement varied seasonally depending on rainfall, as shown in Figure 20. The rate picks are concentrated in the months of February and March, reflecting major rainfall incidents as well as the accumulation of rainfall along the whole rainy season (November-March). The influence of heavy rainfalls in the piezometric levels can be seen in Figure 21.
- Differences in the movement rate were noted among the monitoring locations, as concluded from Figure 22 and Table 2. The depth of the sliding zone, as well as the inclination of the bedrock, which differed significantly across the landslide mass, were the basic parameters that influenced the rate of movement. The empirical factor k ($=\text{depth} \cdot \text{inclination}$) was calculated to define the dependence of the slide rate on the depth and the inclination of the sliding surface at various landslide locations. As expected, the graph of Figure 22 illustrates a strong positive correlation between the mentioned geometrical factors on the landslide velocity (the slide rate increases with depth and bedrock inclination).
- The movements at depth recorded by the inclinometers were in good agreement with the surface movements measured by the optical targets, as listed in Table 3, indicating that negligible differential displacements were observed along the piles of the piers.
- Assuming a construction period of two (2) years for the temporary projects, the design values of the imposed movements due to the slide were set equal to total differential movement between the temporary piers of 30 mm/year in the transverse direction of the bridge, 15mm/year in the longitudinal direction and 25mm/year differential settlement between the piles of adjacent piers of the right branch.

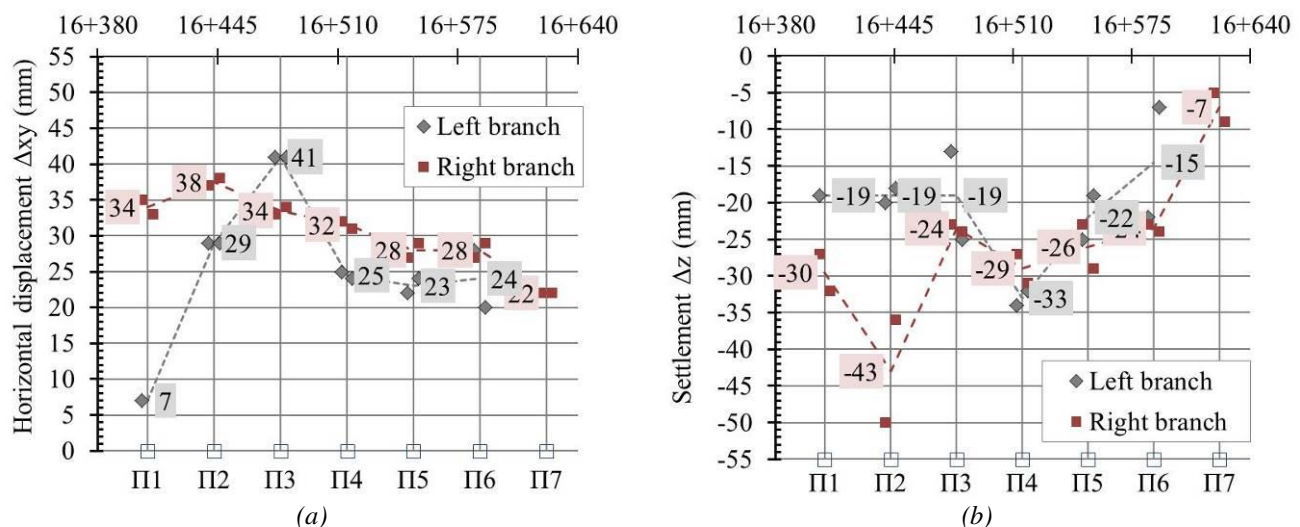

Figure 19. Recorded differential (a) horizontal and (b) vertical displacement between piers (time period 3/13 – 3/14).

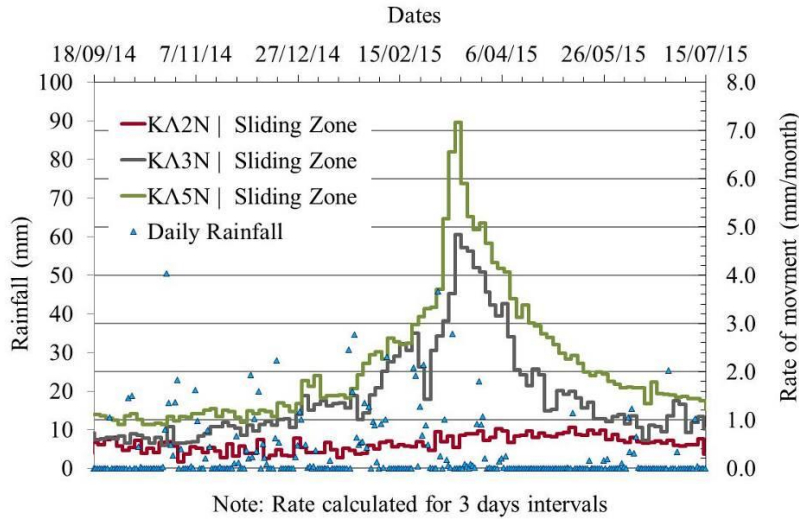

Figure 20. Diagram of slide movement rate with respect to rainfall.

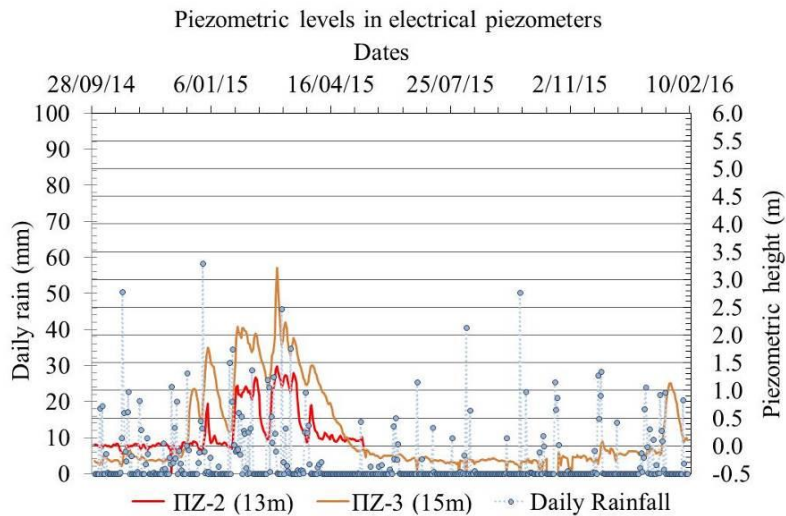

Figure 21. Diagram showing correspondence of piezometric levels to rainfall.

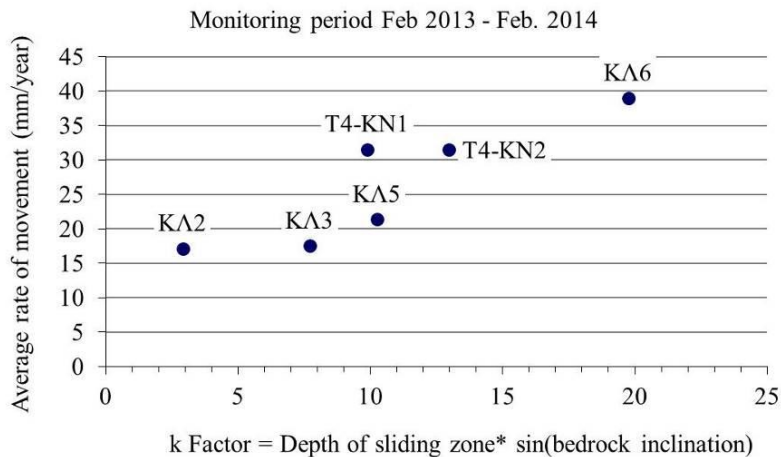

Figure 22. Rate of movement for different locations of the slide zone.



Table 2. Summary of movement of all inclinometers installed for the period 2012 – 2016.

Inclinometer	Period	Slide zone depth (m)	Total movement (mm)	Average rate (mm/year)
Automated				
KA2	01/13 – 06/14	13.5 – 15.0	26.4	18
KA2N	07/14 – 02/16	10.5 – 12.0	8.4	5.4
KA3	01/13 – 05/14	16.5 – 17.5	23.1	17
KA3N	09/14 – 02/16	15.0 – 17.0	19.1	13
KA5	01/13 – 03/14	29.5 – 31.0	35.6	30
KA5N	05/14 – 02/16	27.5 – 29.5	35.2	20
Conventional				
T4-KN1	07/12 – 03/15	14.0 – 15.0	77.1	28
T4-KN2	06/12 – 03/15	19.0 – 19.5	77.5	27
KA6	10/12 – 03/14	39.5 – 40.0	53.4	39
KA6N	05/14 – 04/15	37.0 – 37.5	21.1	20

Table 3. Comparison of deep vs surface movements for the period 28/03/13-7/03/14

Location of reading	Slide zone depth (m)	Mean total annual movement (mm)
Sliding zone T4-KN1 and T4-KN2	15-20	27 (at the sliding zone)
Optical targets on the pile-wall	18-22	25 (at the top of pile cap)
Optical targets on pile caps Π2A, Π3A, Π4A	18-20	29 (at the top of pile cap)
Optical targets on pile caps Π2Δ, Π3Δ, Π4Δ	30-34	34 (at the top of pile cap)
Sliding zone KA5 and KA6	35-40	32 (at the sliding zone)

DESIGN OF THE TOWERS FOUNDATION

Design Criteria

The design of the foundation of the fourteen (14) twin steel towers constituted the greatest challenge of all required temporary infrastructure projects from geotechnical and structural point of view. Their deep foundation design should guarantee the safety of the personnel and the great accuracy required for the welding activities at a maximum height of 60 m, carrying significant loads to the ground without disturbing the susceptible stability of the sliding mass. The steep inclination of the stable bedrock and the continuously moving soil mass downslope shaped the technical framework for the design of the towers foundation. The geological conditions on site, with a bedrock surface at a depth that reached almost 40 m, covered with various mostly loose materials (i.e. debris of landslide, weathered flysch bedrock, colluvia of limestone, recent embankment and fill materials), played an important role on the selection of the most appropriate solution between shallow and deep foundation. Shallow foundations would have been vulnerable to displacements and local instabilities mainly close to the crest of the slope which were not acceptable for construction. The morphology of the construction area of the west arch and mainly near the piers Π1Δ – Π5Δ imposed more restrictions, with the assembling line of the west branch being very close to the edge of the slope seated on the active landslide, as shown in Figure 23. In this specific area, slabs on the ground were also excluded due to the required massive volume of soil mass on the sliding body reaching a height of more than 10 m. Such a load would have increased the already great risk of local failures and extreme displacements leading potentially to catastrophic consequences on the erection and welding of the arches. The alternative of pile group independent for each pier prevailed. The case of long piles was then encountered, exceeding the length of 40 m to reach the bedrock. It was soon rejected because the construction cost would increase disproportionately for a temporary project. The required bearing capacity of piles could be achieved just by friction in the loose material of the sliding mass. It became clear that deep piles would not contribute to the stability of the pile groups against an eventual large scale new activation of the landslide or to even slow down the evolution of movements. Such a solution would only increase the bearing capacity of the piles, but the piles would soon fail from shear at the interface between the moving mass and the bedrock, given the daily movements. Hence, for the right branch, where the bedrock could be found at a depth of more than 40 m, the solution of friction piles floating into the sliding mass was finally adopted. For the left branch, instead, where the thickness of the soil materials was less than 5 m, the piles penetrated the rock, assuring the necessary bearing capacity. The latter was confirmed by two pile load tests of non-operational piles 5 m and 12 m in length, respectively, installed within

the top layers of the soil material. Compression as well as tension tests were performed helping the optimization of the pile design.



Figure 23. Assembling line of the right branch.

It should be clarified that the design of these infrastructure projects did not aim at the stabilization of the landslide, or at achieving satisfactory safety factors for the sliding surface, something that was impossible to obtain for such a massive unpredictable phenomenon. The scope of the design focused on the safety of the whole project during the arch erection providing the necessary stability for the arch erection and the required accuracy of the welding procedures. The fundamental guidelines of the final design were based on the assumptions that these projects were temporary with a functional time that would not exceed a period of two years, and that the rate of the sliding movements would be continuously observed, expecting that it would not differ from the one measured the previous decade, minimizing thus the risk of exposing the works to an increased probability of a new activation of the landslide during the erection of the bridge arches.

Design Methodology

Detailed 2D and 3D analyses were conducted and a stepwise approach was followed to study how the movement of the sliding mass could influence the internal forces of the piles and pile caps of the temporary piers. Taking into account that the main component of soil movement was almost perpendicular to the axis of the bridge, as measured by the geotechnical instruments, a characteristic transverse section between piers $\Pi 2$ and $\Pi 3$ was selected to represent the central area of the landslide (Figure 24), considered to be the most adverse one by means of the movement activity, because of the free height of the piles of the right branch, and the depth and inclination of the sliding surface. In Figure 25 this characteristic section is illustrated. The design methodology included five (5) phases as described in the flow chart of Figure 26. The recommendations and requirements of the Eurocodes or other current codes like DIN4014 were implemented.



Figure 24. Location in plan view of the characteristic transverse view A-A.

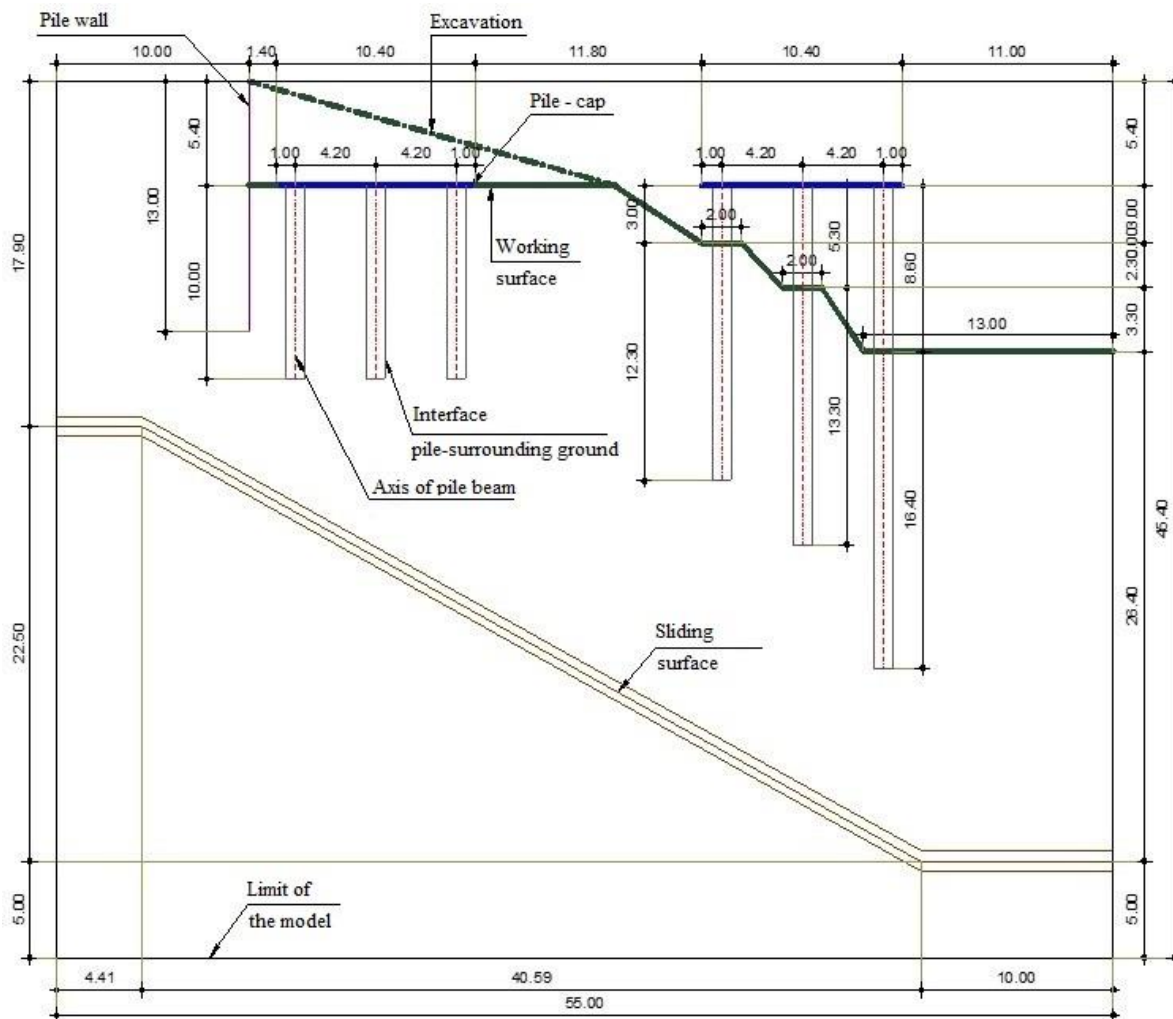

Figure 25. Geometry of the «guide-model» based on the transverse section A-A.

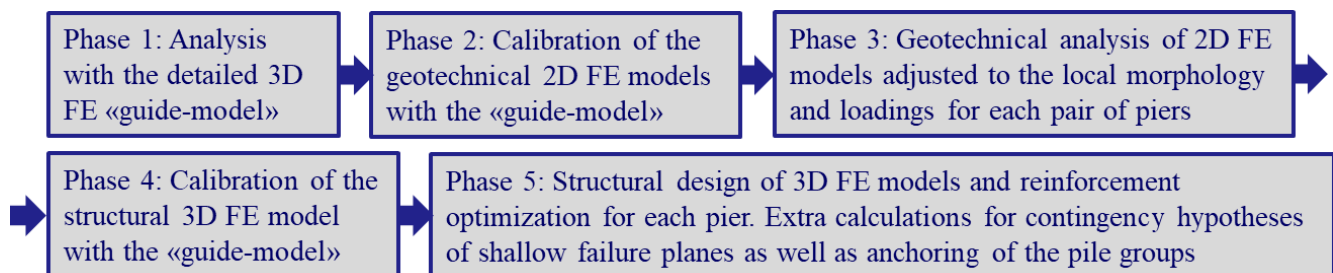

Figure 26. Design methodology – Flow chart.

The geotechnical and structural models used for the analyses were divided in the following three groups (Seferoglou and Vassilopoulou, 2016):

- Because of the complex three-dimensional character of the problem, a 3D finite element model was set up with the software ABAQUS and the analysis results were used as the principal qualitative guidelines for the geotechnical assessments. For this reason, this specific model was defined as the «guide-model». The excitation due to soil mass movements was introduced using the profile of the movements derived from the recording data of the monitoring network. External loading from the superstructure was also taken into consideration.



- Subsequently, a geotechnical analysis was performed with the software PLAXIS, using a 2D model having the same geometry of Figure 25. The scope of this analysis was to calibrate the 2D geotechnical model with the «guide-model» by means of the equivalent stiffness of the structural elements, comparing the internal forces and the calculated displacements. 2D geotechnical analyses for each pair of the fourteen (14) piers proceeded, considering in each case the local morphology of the sliding surface and the local profile of the soil mass movement. In this way, the complex and time consuming procedure of modelling and analysing each pair of piers with the aforementioned method of the «guide-model» was not necessary.
- Finally, using the software SOFiSTiK, the internal forces and displacements of a typical 3D structural model with the geometry of the characteristic section of Figure 25 were compared with the corresponding ones of the «guide-model» showing satisfactory agreement. In the final phase of this procedure, 3D structural models were created for each structural element of the foundation (piles and pile cap of each pier) aiming at the optimization of the dimensioning and the calculation of the required reinforcement. For these structural analyses the required data for the geotechnical parameters were based on the 2D geotechnical analyses performed with PLAXIS.

Analysis of the 3D Finite Element «Guide Model» with ABAQUS

The «guide-model» contained the piers of both branches, meaning the piles and the pile caps, as well as the retaining pile-wall supporting the temporary diversion of the highway. Solid finite elements were used for the surrounding ground, following the Mohr-Coulomb failure criterion, shell finite elements simulated the pile-caps and the pile wall, and beam elements modelled the piles of the piers. Solid finite elements with zero elastic modulus were also used to fill the holes at the ground created by the piles. A symmetry plane was introduced, perpendicular to the longitudinal axis of the bridge, passing from the transverse axis of the piers. Hence, only half of the model is used reducing significantly the calculation time. The boundary conditions of the model and the analysis procedure was based on the methodology proposed by Kourkoulis et al. (2011, 2012). The numerical analysis was performed in seven steps determined by the actual construction stages of the structure:

- Step 1: Geostatic state considering a horizontal ground surface.
- Step 2: Removal of the ground material creating the existing morphology.
- Step 3: Excavation at the level of the pile caps and activation of the shell elements of the retaining wall.
- Step 4: De-activation of the finite solid elements into the holes of the piles, simulating the ground and activation of the beam elements of the piles and the solid elements with zero stiffness.
- Step 5: Activation of the shell elements of the pile caps.
- Step 6: Loads from the towers.
- Step 7: Imposed horizontal movement of 6 cm, accounting for two years of construction (3 cm/year).

Snapshots of the «guide-model» at the characteristic steps of the analysis are provided in Figure 27. The soil displacement due to the imposed horizontal movement at the end of Step 7 is plotted in Figure 28, showing that the slope movement practically led to a uniform displacement of the soil above the sliding surface. The most critical internal forces are calculated for the piles of the right branch due to the morphology of the ground and their significant free height. According to the analysis results, the uniform displacement of the soil mass, caused only a small increase of the internal forces of the piles at the end of Step 7 arising at 3.4% for the axial forces, 4.2% for the shear forces and 37.5% for the bending moments at the connection of the piles with the pile caps, while smaller differences are noted for the buried parts of the piles. The horizontal displacements of the piles of the right branch pier are plotted in Figure 29, showing that at the end of Step 7 the displacements are almost the same along the piles. This leads to the conclusion that no significant differential displacements were introduced to the structure due to the landslide, which was in accordance with the measurements of the geotechnical instruments.

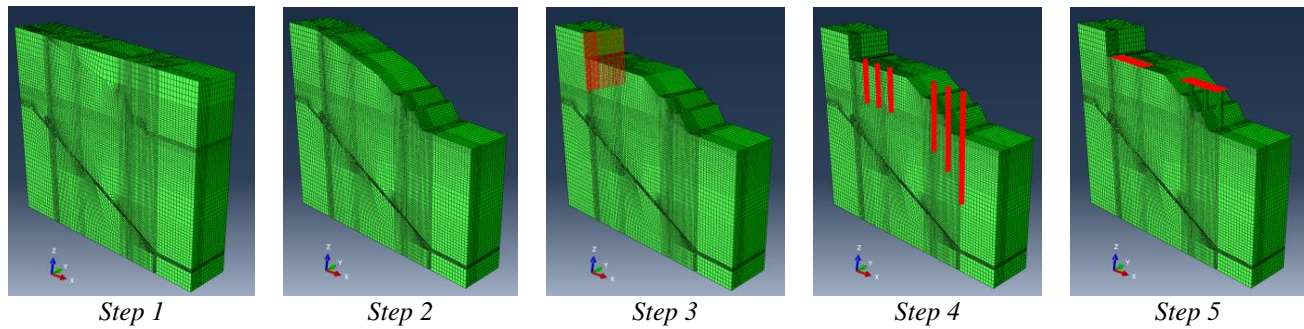

Figure 27. Different steps of analysis for the «guide model».

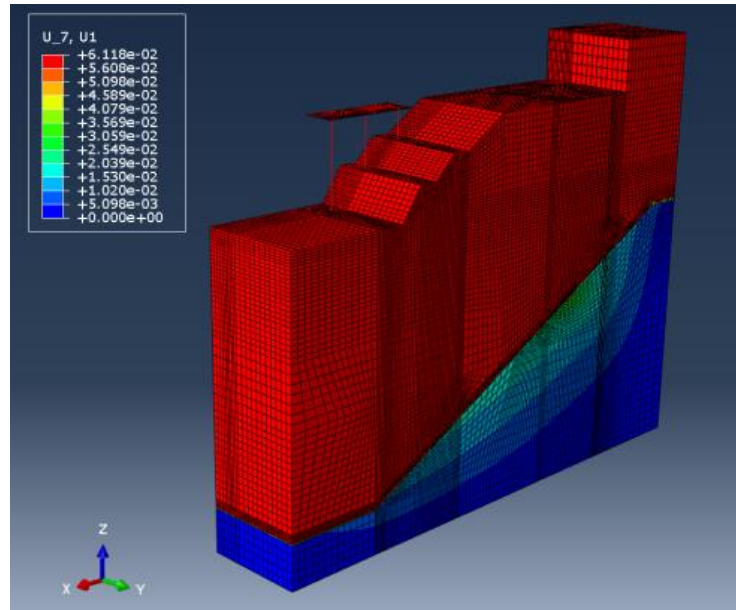

Figure 28. Transverse slope displacement (in m) due to the imposed movement.

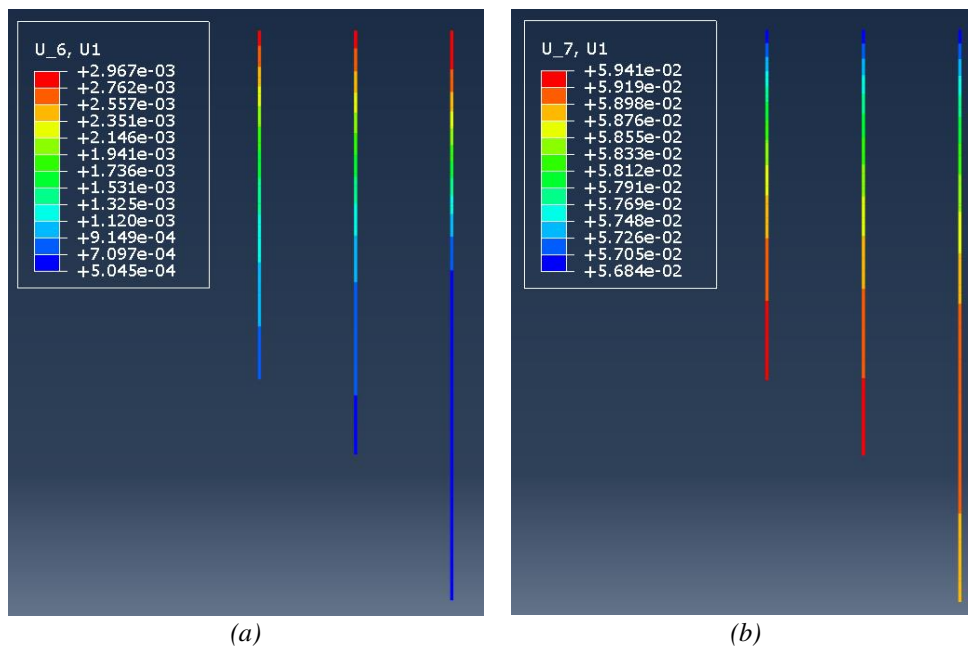

Figure 29. Horizontal displacement (in m) in the transverse direction of the bridge of the right branch piles: (a) Step 6, (b) Step 7.

Analysis of the 2D Finite Element Models with PLAXIS

Addressing to the different morphological conditions of the ground excavations and the geometry of the bedrock surface, each pair of piers should be analysed separately. The 3D geotechnical analysis of the «guide-model» was a very time-consuming procedure by means of the model configuration, the calculation and the elaboration of the results, rendering inefficient the analysis of each of the seven transverse sections of the project with similar 3D finite element models. Therefore, exploiting the results of the 3D analysis, another faster but of similar accuracy approach was adopted setting up several 2D models with the software PLAXIS. First, the calibration of the assumptions and the analyses parameters between the 2D and 3D analyses was achieved. The typical 2D model of Figure 30 was created, based on the geometry of the characteristic section of Figure 25, in which the piles were simulated as an infinite diaphragm with a linearly distributed stiffness that corresponded to 2 piles in series. The internal forces of the piles at each step of the analysis and the slope displacements due to the imposed movements were compared with the corresponding ones of the «guide model», showing very good agreement. The geotechnical parameters and the assumptions regarding the construction phases and the imposed slipping movements were similar to the ones considered for the 3D geotechnical analysis. Five (5) analyses steps were taken into account, as follow:

- Step 1: Geostatic state.
- Step 2: Excavation and construction of the pile wall retaining the temporary diversion of the highway.
- Step 3: Construction of the towers foundation (piles and pile caps).
- Step 4: External loads from the towers, applied on the pile caps.
- Step 5: Imposed horizontal movement of 6 cm.

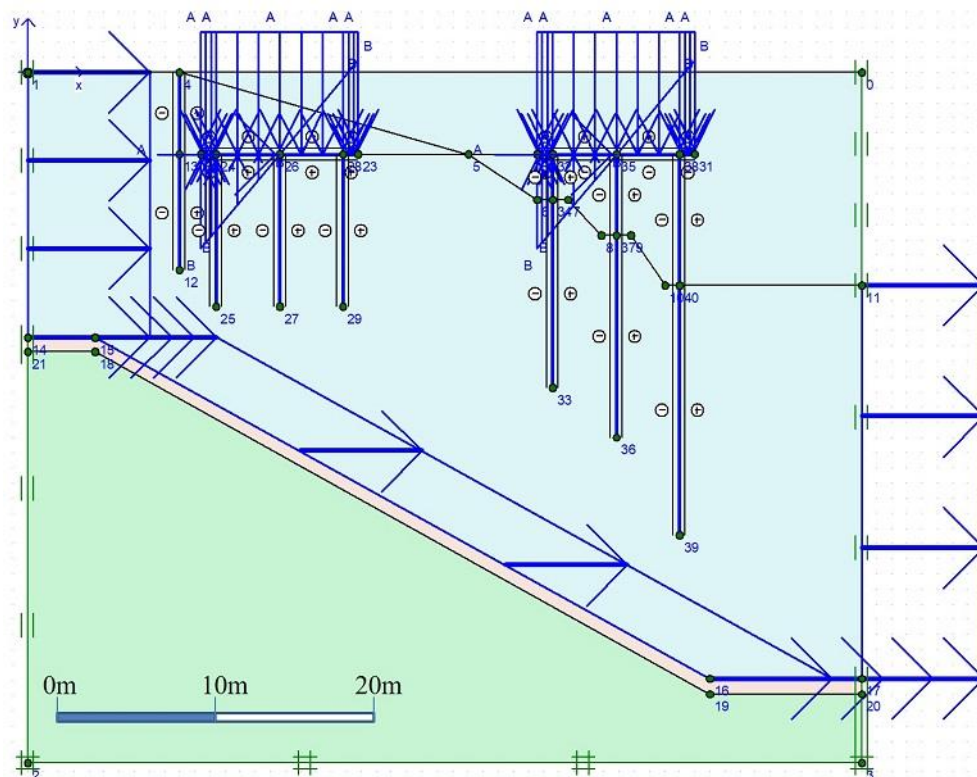

Figure 30. 2D finite element model used for the calibration of PLAXIS with the «guide model».

Thereupon, seven models were created for each pair of piers, illustrated in Figure 31, representing not only the geometrical characteristics of each pier, by means of the pile lengths and pile-cap dimensions, but also the different morphology of the surrounding ground and the geometry of the bedrock surface. The geometry of these models is derived by the sections



shown in Figures 6 through 8 and 16. The scope of this procedure aimed at defining the geotechnical parameters that would feed the final structural design of each pier. These parameters were the coefficients of the earth pressure produced by landslide slippage and the constants of the equivalent elastic supports that would be applied as springs at the bottom of each pile of the structural models, simulating the soil-structure interaction. The constant of equivalent vertical spring of each pile of the piers was expressed as $K=P/v_z$, where $P=1000$ kN was a single load applied on the top of the corresponding pile and v_z was the calculating settlement. For the piles of the left branch a mean value derived from the analyses of all piers and a spring constant of 140,000 kN/m was adopted, while for the right branch the calculated values varied within a range of 120,000 kN/m – 1,000,000 kN/m. These results were in accordance with the ones derived from loading tests of non-functional piles. Regarding the earth pressure evolved at the upslope piles of the right branch piers $\Pi 2\Delta$ - $\Pi 4\Delta$, presenting the maximum free height and being founded in the sliding body, the horizontal and vertical stresses were calculated under static loads, resulting in equivalent pressure coefficient equal to $K_0=0.50$. The same value was obtained for the imposed movement, since the floating piles moved along with the sliding mass, as also demonstrated by the 3D geotechnical analyses and confirmed by the monitoring data.

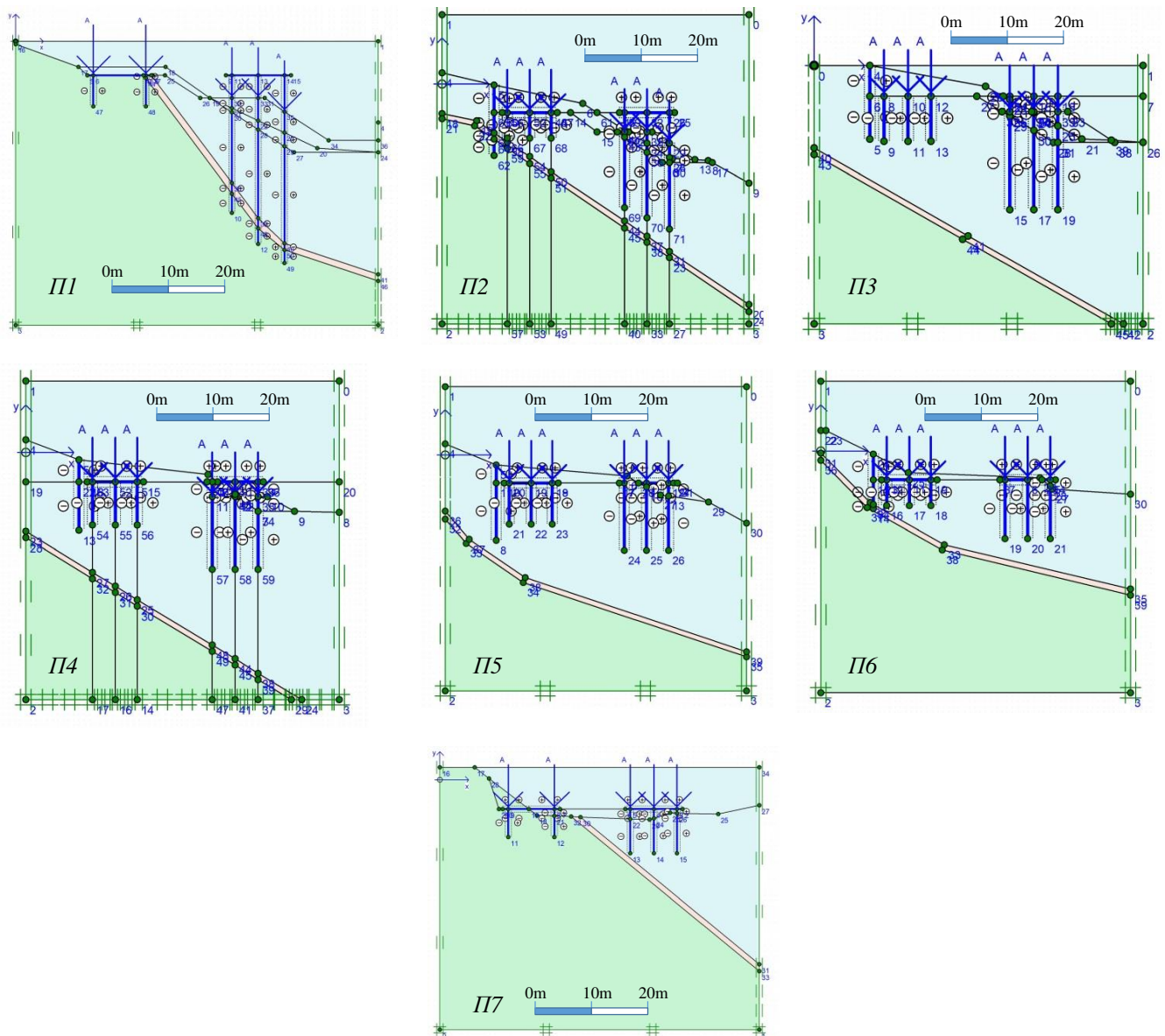

Figure 31. Models of each pair of piers for the 2D geotechnical analyses.

Analysis of the 3D Finite Element Models with SOFiSTiK

Proceeding with the final structural design of the piers, which would lead to the optimization of the dimensioning and the calculation of the required reinforcement of their structural components, first the calibration of the static results with the ones derived by the previous analyses was obtained. For this reason, a structural model was set up, shown in Figure 32, based on the characteristic transverse section of Figure 25. The soil-structure interaction was simulated by horizontal springs along the piles and vertical ones applied at their base, extracted from the PLAXIS analyses. The load cases considered for this analysis were the self-weight, the loads coming from the towers and the earth pressure with coefficient $K_0=0.50$. Based on the instruments' measurements and the analysis of the «guide-model», which resulted in insignificant differential displacement along the piles of each pier, no imposed ground movement was taken into account. Comparing the internal forces of the piles with the corresponding ones calculated for the «guide model» negligible differences were noticed. Afterwards, further numerical analyses followed for each pier, taking also into account the seismic action with a reduced ground acceleration due to the temporary character of the project equal to $0.08g$, and an importance factor equal to $\gamma_I=1.30$, as assumed for the whole project of the bridge, accounting for the increased seismic hazard conditions and public safety. Two contingency working hypotheses were also considered. The first one pointed out eventual local shallow failure planes developed at depth of 8 m – 10 m from the ground surface introducing a 15 mm transverse movement (Figure 33) and the second one imported the forces from the anchoring of the pile caps (Figure 34) in case the measured movements exceeded the permissible limits or the tolerance of the superstructure during the erection and welding of the steel arches. The maximum required longitudinal reinforcement of all loading combinations was calculated at the top of the piles of piers $\Pi 2\Delta - \Pi 5\Delta$. The internal forces developed at these points were compared with the corresponding ones derived at the last step of the analyses with PLAXIS, after the movement due to the slipping mass was imposed. The comparison indicated that the imposed soil movement increased the axial forces by 2.5% and the bending moments by 6%. Therefore, it was decided to increase the reinforcement by 10% for the piles of the specific piers to take the sliding phenomenon into account.

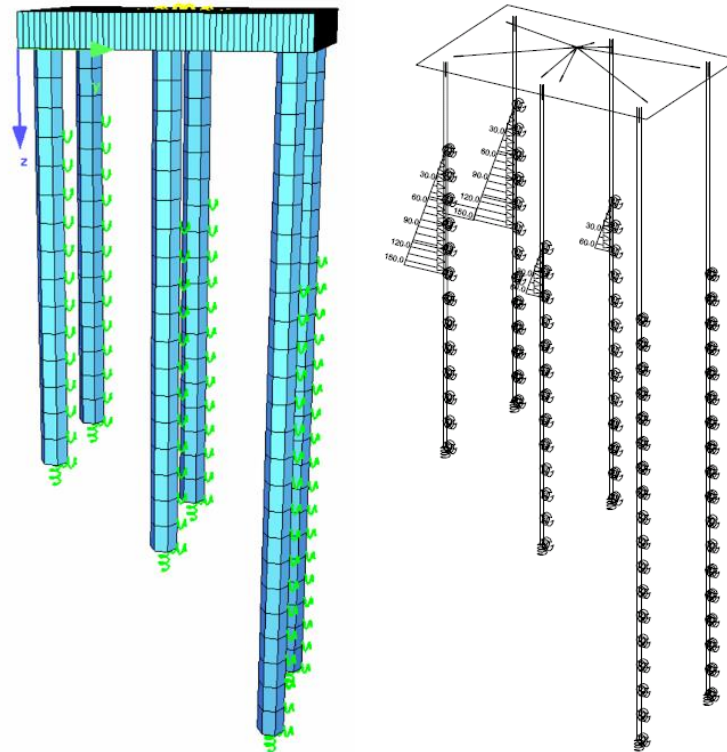

Figure 32. 3D finite element model for the calibration of SOFiSTiK.

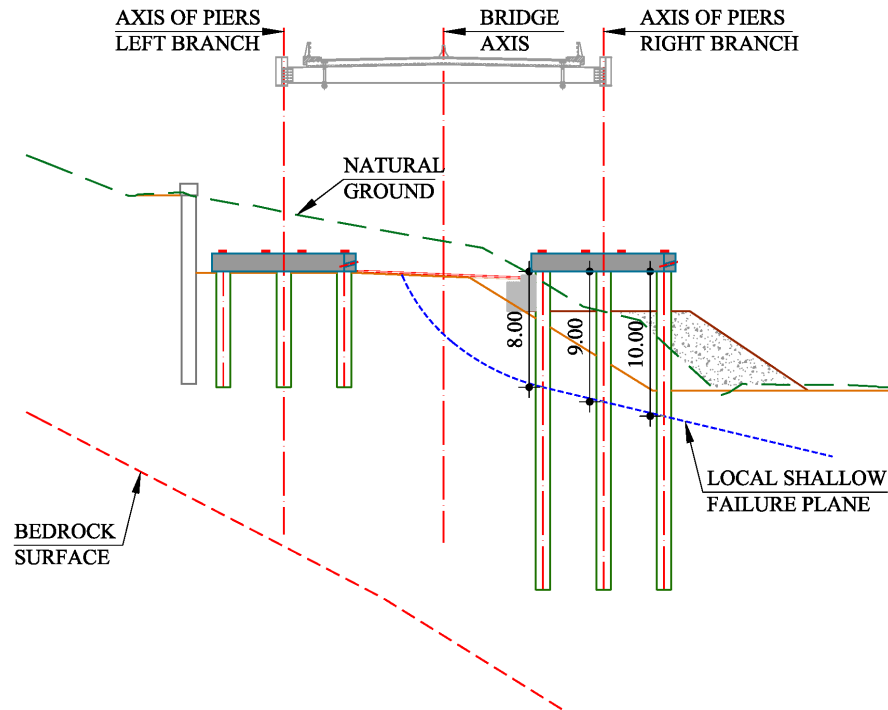

Figure 33. Contingency local shallow failure planes.



Figure 34. Contingency plan for anchoring of the pile caps.

SUMMARY AND CONCLUSIONS

This paper presented the methodology followed for the geotechnical and structural design of the fourteen (14) auxiliary towers foundation, which were mounted for the erection of the arch of the Tsakona Bridge in southern Peloponnese, Greece. The deep foundation of each tower was formed as a pier, consisting of a group of piles, connected with pile caps. The moving body of the active landslide, overpassed by the arch of the bridge, was decided to be used as the foundation ground of all temporary infrastructure projects. Due to the high risk and uncertainties of the landslide phenomenon, during the construction of the bridge, the evolving movements of the sliding mass were continuously recorded, analysed and evaluated by an instrumentation and automated monitoring network installed in the area.



The design of the piers resulted in deep foundations with floating piles into the landslide body as the most efficient and cost-effective solution. 2D and 3D geotechnical models were created to investigate the behaviour of the piers subjected to the movement induced by the sliding mass, considering the exact geometry of the ground morphology and the sliding interface at each pier position. The main conclusion drawn from these numerical analyses was that the moving mass was slipping uniformly, without influencing significantly the internal forces of the piles. This conclusion was also confirmed by the measurements from the monitoring system. The geotechnical analyses also designated the geotechnical parameters that were later used for the final structural design of the piers, by means of spring elastic constants and earth pressure coefficients. The internal forces of the piles calculated by the structural analyses under static and seismic loading combinations were compared with the ones derived by the geotechnical analyses, which considered the influence of the sliding movements on the structural components. A small increase was noted due to the sliding movements, thus a 10% increase of the reinforcement was decided for the piles of the most critical piers.

ACKNOWLEDGEMENTS

The design and construction of the project has been supervised by the Greek Authorities (DMEO, D1, EYDE/DDP) of the Ministry of Infrastructure, Transport and Networks. The contractor of the project was initially the J/V TERNA S.A. - ALPINE BAU and then TERNA S.A. The design and construction team consisted of the following: Structural design of the Tsakona Bridge: DOMI S.A; Geotechnical and foundation design of the Tsakona Bridge: EDAFOS S.A.; Design of infrastructure projects and construction consulting: ODOTECHNIKI Ltd.; Design of heavy lifting scaffolding: PERI Formwork Scaffolding Engineering; Steel fabrication and erection: EMEK S.A.; The construction consulting team of ODOTECHNIKI Ltd consisted of: K. Seferoglou, Civil (Geotechnical) Engineer, M.Sc.; I. Vassilopoulou, Dr. Civil (Structural) Engineer; P. Fortsakis, Dr. Civil (Geotechnical) Engineer; F. Chrysohoidis, Engineering Geologist M.Sc., DIC; G. Prountzopoulos, Dr. Civil (Geotechnical) Engineer; K. Nikas, Civil (Geotechnical) Engineer, M.Sc.; X. Botopoulos, Civil (Structural) Engineer. Consulting support on optimization of ABAQUS by Prof. I. Anastasopoulos and K. Tzivakos, Civil Engineer.

The construction of the Tsakona Bridge, especially during the erection of its arch, was menaced by too many uncertainties, adversities and risks. Only with the tuned collaboration between the geotechnical and structural teams, the designers and the construction team along with the support of the consultants allowed the successful completion of such a complex project. The impressive bridge stands safely since March 2016 enhancing the beauty of the landscape and feeding with pride those who were involved in the project.

REFERENCES

- ABAQUS v.6.12 (2012). Finite Element Software, Dassault Systèmes Simulia Corp., Providence, RI, USA.
- Belokas, G. (2013). "The Tsakona landslide in Peloponnese – Greece." The Mediterranean workshop on landslides (MWL), Napoli, Italy.
- Belokas, G. and Dounias, G. (2016). "The Tsakona landslide in Peloponnese – Greece." *Rivista italiana di geotecnica*, 1, 34.
- DIN 4014 (1990). "Bored cast-in-place piles – Formation, design and bearing capacity." Beuth Verlag.
- EMEK S.A (2015). "Tsakona Bridge (Arcadia county, Greece) - Main Road Tripoli – Kalamata" <<https://vimeo.com/146397999>>.
- European Committee for Standardization (2004). "Design of concrete structures – Part 1: General rules and rules for buildings.", *EN 1992-1-1*, Brussels.
- European Committee for Standardization (2005). "Design of concrete structures – Part 2: Concrete bridges.", *EN 1992-2*, Brussels.
- European Committee for Standardization (2004). "Geotechnical design – Part 1: General rules.", *EN 1997-1*, Brussels.
- European Committee for Standardization (2005). "Design of structures for earthquake resistance - Part 2: Bridges.", *EN 1998-1*, Brussels.
- European Committee for Standardization (2004). "Design of structures for earthquake resistance - Part 1: General rules, seismic actions and rules for buildings.", *EN 1998-1*, Brussels.
- Fikiris, I. F., Dounias, G. T. and Sotiropoulos, L. (2011). "Foundation of the arch bridge in the landslide area of Tsakona, Greece." *Proc., 15th European Conference on Soil Mechanics and Geotechnical Engineering*, "Geotechnics of Hard Soils – Weak Rocks", Athens, Greece, 2, 717-722.

**The International Journal of Geoengineering Case Histories
(IJGCH) is funded by:**



Email us at main@geocasehistoriesjournal.org if your company wishes to fund the ISSMGE International Journal of Geoengineering Case Histories.

The open access Mission of the International Journal of Geoengineering Case Histories is made possible by the support of the following organizations:



Access the content of the ISSMGE International Journal of Geoengineering Case Histories at:
<https://www.geocasehistoriesjournal.org>